



50:1 Grease Pump Kits

Models L6810A

Read the following precautions and instructions before you begin assembly or using. Failure to comply with these instructions could result in personal injury or property damage. Keep these instructions in a convenient location for future reference.

Important Note

The guarantee will be void if the pump has been altered in any way

Profile

Grease pumps are designed for transferring grease from drum to where it would be used.

- Compressed air operated reciprocating pumps are designed for high pressure greasing.
- Be applicable to the manipulation of all types of grease (up to NLGI-2 consistency) from its original drums.
- The pumps can be supplied as separate components or as a complete system with all the elements - necessary for its installation.

- The pumps can be assembled on mobile units as well as on fixed positions, connected to steel pipes. This manual is applicable to the following models listed above, please confirm your pump is included.

Specifications

Item No.	L6810A
Pump ratio	50:1
Operating pressure(psi / bar/)	70-115 / 5-8
Maximum pressure(psi / bar)	115/8
Air consumption(CFM L/min)	4.3 / 120
Delivery (lbs/min gms/min)	1.56 / 700
Tube diameter(inch/mm)	1.18 / 30
Air inlet connection	1/4" quick plug/1/4" NPT female
Grease outlet connection	Male 1/4"
Noise level(dB)	82

Troubleshooting

Problem	Possible Causes	Solutions
The pump continues to operate after the gun trigger has been released	1. Grease missing around the suction filter 2. There is a grease leak at some point of the circuit 3. Valve(part No. 15) closes incorrectly due to dirt or wearing.	1. Remove cover and take out pump and follower plate. Compact grease and fill the drum or substitute it for a full one. 2. Check and tighten unions. Repair the leak. 3. Disassemble and clean valves. Substitute them if damaged.
Reduction of the grease delivery. Or reduced pressure in the grease delivery.	1. Air bags in the grease drum 2. Silencer(210) dirtied 3. Blocked at some point of the grease circuit 4. Ball valve (103) closes incorrectly due to dirt or wearing. 5. Damaged O-ring(216)	1. Remove the cover and take out the pump and the follower plate. Compact the grease and fill the drum 2. Clean or recharge silencer 3. Use clean grease 4. Substitute damaged elements
Air loss through the air exhaust	1. The sliding valve (7) does not close properly 2. The press piece(36) broken 3. Damaged O-ring(208, 209 or 211) 4. Damaged piston (2) 5. Damaged washer(31) 6. Broken spring (33)	1. Disassemble and clean. Substitute them if damaged 2. Substitute damaged elements
Grease leaks through the air exhaust	Seal set (11) damaged	Substitute damaged elements

If the pump has anything wrong, please contact dealer or their technical support.

Storage and Maintenance

Pumps are delivered in appropriate cardboard boxes. Packaging material should be properly disposed. Handling and storage of the new pump do not require any special procedures.

The dust in compressed air can slow down or even block the motor cylinder. The following steps may prevent this from happening:

- 1) Let in 50 gram of air tool oil into from the air inlet hole weekly operate the pump for several minutes after having lubricator into the pump.
- 2) Turn on the pump for several minutes until moving parts is fully lubricated.
- 3) You may repeat the above operation if necessary.
- 4) The above steps should be carried out on a weekly base.

For the pumps that are attached with compressed air treatment equipment please empty the water retained in the reservoir of the filter-purger frequently.

For the pumps that are attached with a lubricator, please pay close attention to the lubricator's oil level and refill with air tool oil when necessary.

NOTE:

The user should perform only routine maintenance operations (such as filters, silencers, cleaning...) in order not to damage it or compromise its safety. Contact our sales or service centers when the pump needs further maintenance.

General Safety Regulations

When the pump is connected to the compressed air supply:

- The compressed air must be filtered to avoid dust into pump
- The max compressed air pressure must not exceed 115 PSI / 8 bar.
- To deliver grease, pull the trigger on the delivery gun; delivery stops when the trigger is released but the whole system remains under pressure.
- Position the gun so that the circuit can't open accidentally. Otherwise grease could leak onto the ground.
- Never point the gun at people
- Pull the trigger only after you are sure that the gun is engaged on the fitting so that the grease doesn't leak onto the ground.
- Always cut off the air supply after use so that grease can't leak out in case one of the pump's components should break
- Use only original spare parts in case the pump has to be repaired or its components have to be replaced
- Ensure the tightness of all joints and screwed unions.

- When no load, cut off compressed air to stop pump.
- Do not use the pump near open flames. Do not smoke during this operation.
- Wear oil-proof gloves
- The pumps can be used only to deliver grease. Do not use the pump for any other substance. Please contact us if you have any special request.

How to Use

- When the pump is applied to a high viscosity grease, or used in low temperature, a grease follower plate is recommended to avoid air pockets and to get the most out of your grease. The follower plate, which is pulled towards the bottom of the drum by suction pressure produced by the air operated pump, compresses the grease, preventing the formation of air pockets which may cause a blockage in delivery. And the follower plate will always keep the grease clean to preserve its characteristics and also enable the grease to be collected from the bottom of the drum to avoid waste.
- Loosen the bung adaptor or wall bracket adaptor star nut. Slide the bung adaptor off of the suction tube.
- Carefully place the pump through the bung adaptor and the follower plate. Then tighten the star nut firmly in order to attach the pump.

Connection of the Air Inlet Line

Air inlet connection is 1/4" quick coupling (or 1/4" NPT female) in all versions.

Compressed air connection (to be supplied by the customer) should be done using suitable tubes.

A compressed air treatment unit (filter and regulator) is recommended to be attached to the pump. In order to improve the efficiency of the pump, the installation of a lubricator is also recommended.

Connection of the Regulator

The lubricator (I) must be placed as close as possible to the air inlet, followed by the pressure regulator (II) and finally, the filter (III). In the case of pumps not installed on wall support it is very important to equip the pump's air inlet with an adaptor for quick coupling and the air inlet hose with a quick connector.

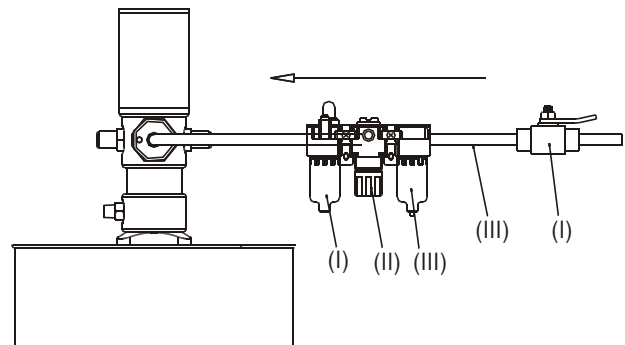

Connection Of Grease Discharge

1. The Grease discharge outlet is a 1/4" thread.
Connect the outlet to the high pressure hose (according to DIN-SAE norms) through the corresponding adapter and terminal.
2. Ensure the gun or corresponding valve is closed.
3. Slowly open the pump's compressed air inlet valve.
The pump will start to function, filling the feed circuit with grease. Maintain pressure on the gun until the grease starts to come out. The pump is now ready for its usual function.

Pump Operation

If the pump has already been primed and the compressed air feed is connected to the appropriate work pressure level (70-115 PSI,) the pump will start automatically when the nozzle or gun situated at the end of the grease delivery circuit is opened.
To stop the pump, simply close the nozzle or disconnect the air inlet line.

Connect The Pump With Other Accessories:

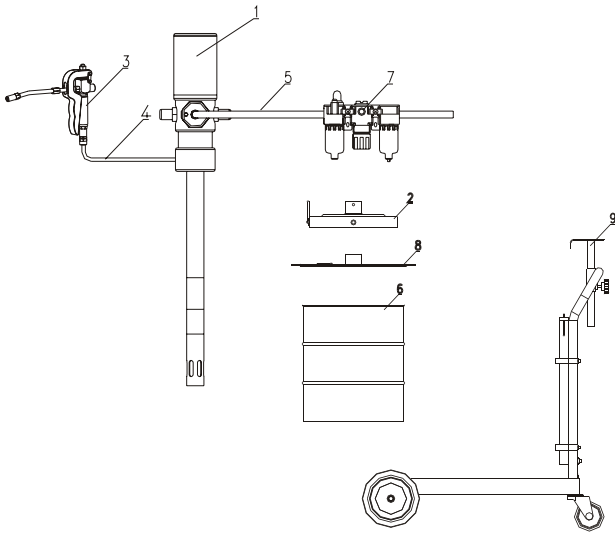

Code	Name
1	Grease pump
2	Drum cover
3	Grease control valve
4	Hose with fitting
5	Air hose with quick coupling
6	Drum
7	Filter, pressure regulator and lubricator
8	Follower plate
9	Trolley (L6821A only)

Pressure Relief Procedure

To reduce the risk of serious bodily injury, including fluid injection, splashing in the eyes or on the skin, or injury from moving parts, please always follow this procedure whenever you shut off the pump, check or service any part of the spray/dispensing system, install, clean or change gun/nozzles, and whenever you stop dispensing.

1. Shut off the air to the pump.
2. Point the outlet of grease gun to container and trigger the grease gun to relieve pressure.

Important Notes:

1. If you suspect that the gun/nozzle or hose is completely clogged, or that pressure has not been fully relieved after following the steps above, **VERY SLOWLY** loosen the retaining nut or hose end coupling and relieve pressure gradually, then loosen completely. Now clear the gun/nozzle or hose.
2. On the pump downstroke, the shovel washer extends beyond the intake cylinder to pull the material into the pump. The shovel washer works under extreme force. During operation and whenever the pump is charged with air, the shovel washer can severely injure or amputate a hand or finger, or break a tool, if caught between it and the intake cylinder. Always follow the Pressure Relief Procedure before checking, clearing, cleaning, flushing or servicing any part of the pump.
3. This equipment conducts very high fluid pressure. Spray from the grease gun, leaks or ruptured components can inject fluid through your skin and into your body and cause extremely serious bodily injury, including the need for amputation. Also, fluid injected or splashed into the eyes or on the skin can cause serious damage.
NEVER point the grease gun at anyone or at any part of the body.
NEVER put hand or fingers over the nozzle.
ALWAYS follow the Pressure Relief Procedure before cleaning or removing the nozzle or servicing any system equipment.
NEVER try to stop or deflect leaks with your hand or body.
Be sure equipment safety devices are operating properly before each use.

4. Any misuse of the system equipment or accessories, such as overpressure, modifying parts, using incompatible chemicals and fluids, or using worn or damaged parts, can cause them to rupture and result in fluid injection, splashing in the eyes or on the skin, or other serious bodily injury, or fire, explosion or property damage.

NEVER alter or modify any part of this equipment; doing so could cause if any malfunction.

CHECK all equipment regularly and immediately repair or replace worn or damaged parts.

System Pressure should **NEVER** exceed the recommended working pressure or the maximum air inlet pressure stated on your pump

Be sure that all dispensing equipment and accessories are rated to withstand the maximum working pressure of the pump. **DO NOT** exceed the maximum working pressure of any component or accessory used in the system.

Fluid Compatibility

The system is only suitable for grease.

5. High pressure fluid in the hoses can be very dangerous. If the hose develops a leak, split or rupture due to any kind of wear, damage or misuse, the high pressure spray emitted from it can cause a fluid injection injury or other serious bodily injury or property damage.

TIGHTEN all fluid connections securely before each use. High pressure fluid can dislodge a loose coupling or allow high pressure spray to be emitted from the coupling.

NEVER use a damaged hose. Before each use, check the entire hose for cuts, leaks, abrasion, bulging cover, damage or movement of the hose couplings. If any of these conditions exist, replace the hose immediately. **DO NOT** try to mend it with tape or any other device. A repaired hose cannot safely contain the high pressure fluid.

Drum Cover and Follower Plate Installation

Put the drum cover onto the drum and tighten the three lock screws.

Put the follower plate into the grease drum, push it down as much as possible to exhaust the air between follower plate and grease.

Kits List

Item No.	L6810, L6810A	L6820, L6821
50:1 Ratio pump	L6815	L6825
Drum application	35 lbs	120 lbs
Drum trolley	DC5-1	DT16
Drum cover	DC5-1	DT16-1
Follower plate	GFP35	GFP120
1/4"x13' connection hose	LH1415614F	LH1415614F
Grease gun	LCG5	LCG5
Z-swivel	LCZ5	LCZ5

Item No.	L6830
50:1 Ratio pump	L6835
Drum application	400 lbs
Drum cover	DC55-1
Follower plate	GFP400
Grease gun	LCG5
Z-swivel	LCZ5

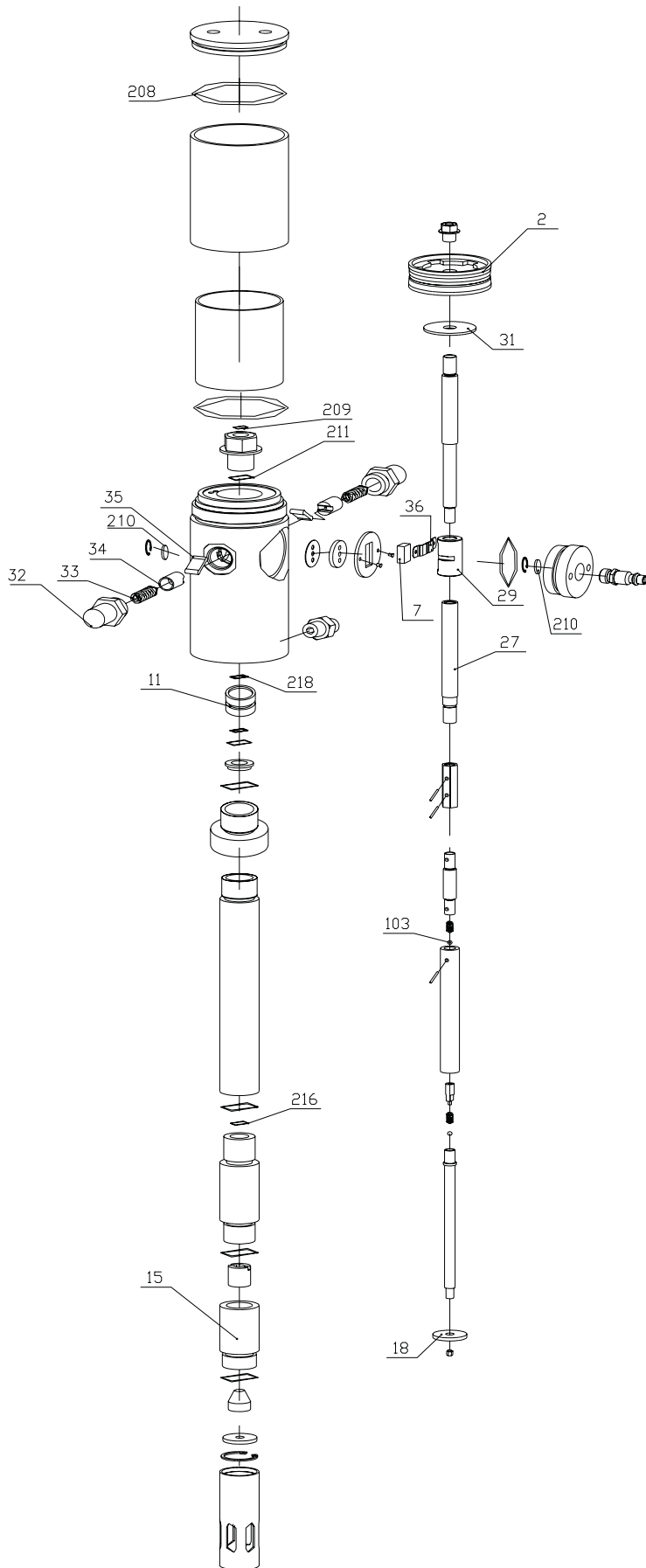

50:1 Grease Pump Repair Part Kit RP009080

Ref	Description	Q'ty
2	Piston	1
7	Slider	1
11	Bracket	1
15	Valve seat	1
18	Shovel washer	1
27	Middle shaft	1
28	Air center cover	1
29	Slider shell	1
31	Washer	2
32	Spring shell	2
33	Spring	2
34	Spring Seat	2
35	Trip shoe guide	2
36	Press piece	1
103	Ball	2
208	O-ring	2
209	O-ring	2
210	Silencer	2
211	O-ring	1
216	O-ring	1
218	OD-ring	2

WARRANTY*

LEGACY MANUFACTURING COMPANY (“LEGACY”) warrants that this equipment will be free from defects in material and workmanship for a period of five (5) years from the date of purchase, under normal use.* LEGACY’S sole obligation under this warranty is limited to replacing or repairing, free of charge, any equipment that proves to be defective under normal conditions and use according to the recommendations of LEGACY. To obtain repair or replacement, the equipment must be shipped to a LEGACY authorized Warranty and Service Center during the warranty period, transportation charges prepaid, with proof of date of purchase. In the event of repair or replacement, the warranty period shall not be extended beyond the original warranty period.

* If this equipment contains a hose, the hose is warranted for ninety (90) days only. The remaining portions of this equipment are warranted for five (5) years, as described above. While necessary maintenance or repairs on your Legacy equipment can be performed by any company, we recommend that you use only authorized Legacy service centers. Improper or incorrectly performed maintenance or repair voids this warranty. Contact us at service@legacymfg.com or www.legacymfg.com for ordering, installation instructions or a list of authorized service centers.

**Legacy Manufacturing Company
Marion, IA**

**Ph: 800.645.8258
Fx: 319.373.7309
service@legacymfg.com
www.legacymfg.com**